

# General information

## Cavity

Type series: C1630

### Dimensions and sectional view

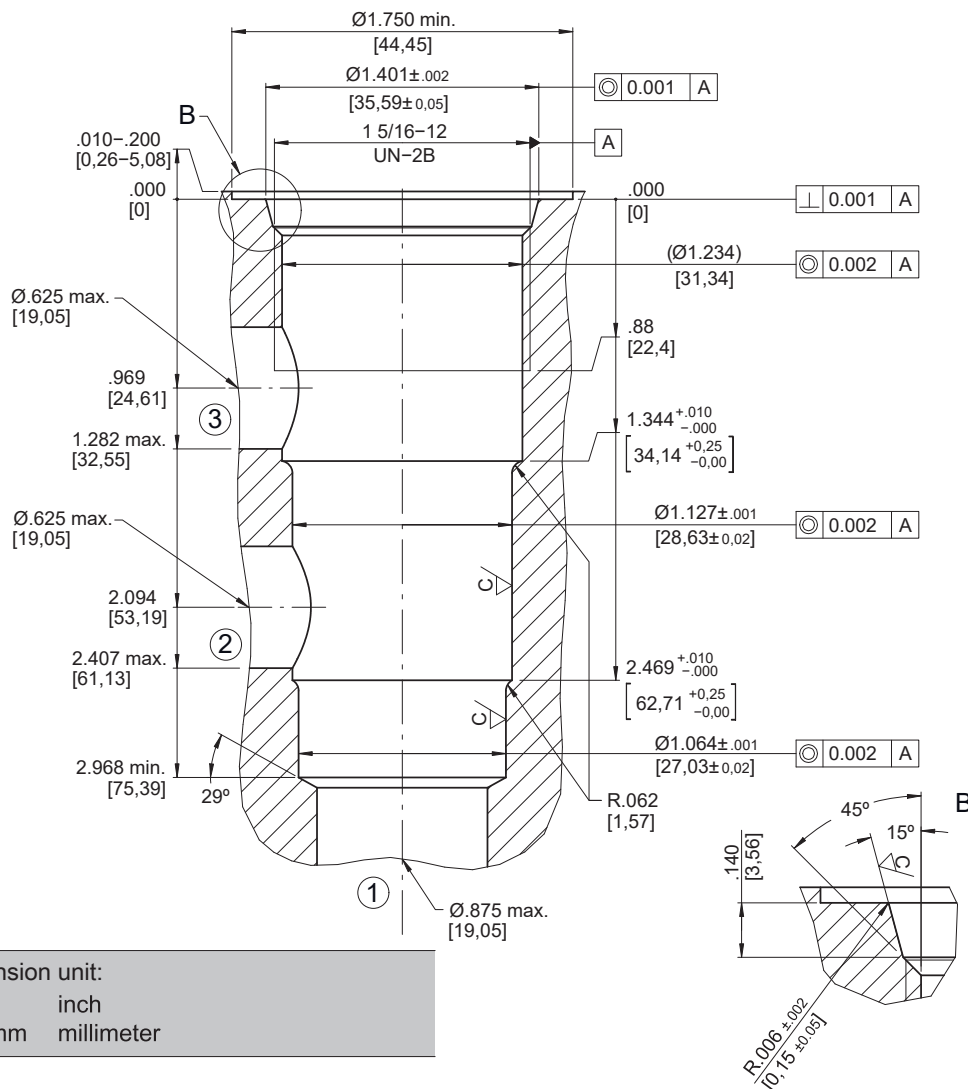

Example dimension unit:  
 .010 = .010" inch  
 [0,79] = 0,79 mm millimeter

Dimension Tolerances	
Unless otherwise specified	
0.000	± .005"
0.00	± .010"
Angles	± 1/2°

Surface roughness		
	C	D
Ra	45 µin ( 1.15 µm )	125 µin ( 3.2 µm )
	D	Unless otherwise specified

## Installation information

**ATTENTION!**

You must maintain the specified positional and diametral tolerances. To ensure trouble-free operation of the screw-in cartridges, we strongly recommend that pilot drilling, boring, reaming and cavity thread-cutting are always performed in one setup.

**NOTE!**

Cavity type to factory standard.

**NOTE!**

We offer form tool sets for sale or hire. See data sheet 520-P-000050 for further information.